

## Combating Damage Caused By Clamp Trucks

**VBoard® solution eliminates a problem that costs manufacturers millions of dollars per year in rejected shipments**

An innovative custom VBoard solution can help manufacturers of large appliances eliminate the damage caused to their packaging by clamp trucks.

Instead of forklifts and pallets, many manufacturers are using clamp trucks to quickly load, unload and store product. The problem that is often encountered with clamp trucks is that they can crush boxes side-to-side during the loading process.

When a clamp truck picks up a unit to load it into a trailer, it can exert up to 2,000 pounds of pressure side-to-side. This can cause damage and wrinkling of corrugated boxes and sometimes damage to the product inside.

Retail customers who receive loads with any crushed or wrinkled boxes often reject the entire load. These rejected loads then have to be returned to distribution centers for inspection and repackaging before being reshipped.

The rejected shipments have cost some manufacturers several million dollars per year, including reshipping and repackaging costs and replacement of any damaged product.

Laminations' packaging experts analyzed this situation, ran compression tests in Great Northern's lab testing facilities, and developed a cost-effective solution that prevents packaging and product damage from the side-to-side pressure of the clamps. It also integrates easily into current packaging systems.

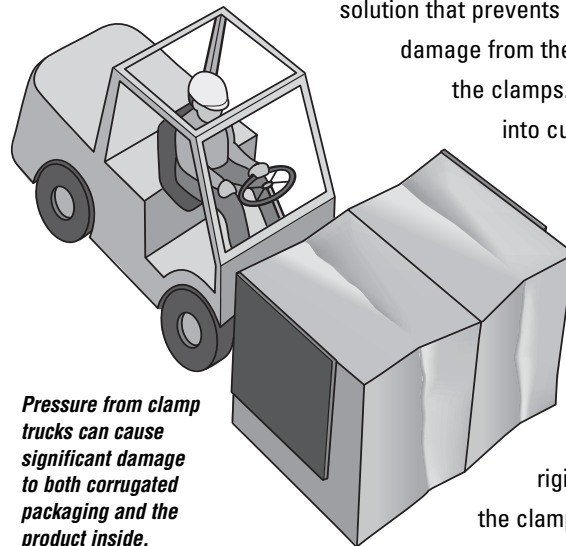

The solution is to use heavy-duty VBoard on the interior or exterior of the boxes to add transport stability to the packaging.

The VBoard adds the rigidity needed to prevent the clamp truck pressure from affecting the corrugated.

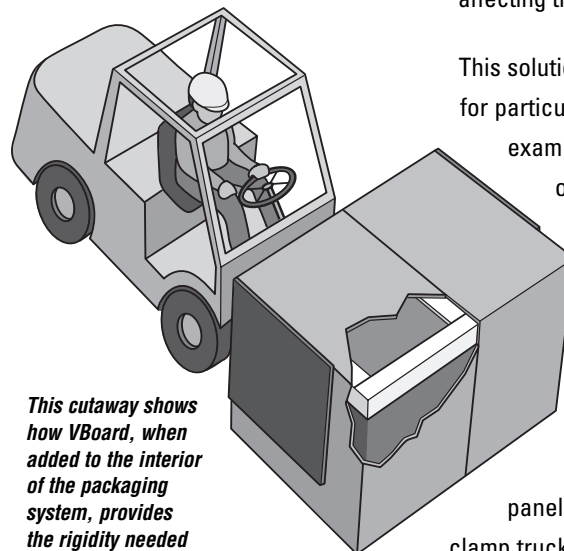

This solution can also be customized for particular applications. For example, for a manufacturer of stacked washer/dryer units, the VBoard is connected to a piece of foam, then positioned horizontally across the front of the packaged units. This acts as a brace between the foam panels that are gripped by the clamp trucks.

In both laboratory tests and on-the-job trials, these types of VBoard solutions have eliminated the problems caused by the clamp trucks, including any crushing or wrinkling of the packages and any product damage.

[www.laminationsonline.com](http://www.laminationsonline.com)

SIC Codes:

3595, 3621